

PRODUCT INFORMATION

FOR YOUR INQUIRIES, PLEASE
INDICATE MODEL NO., AND FOLLOWING
CATALOGUE NUMBER
SHE001

TV-2 WALL BRACKET FOR TV/MONITOR

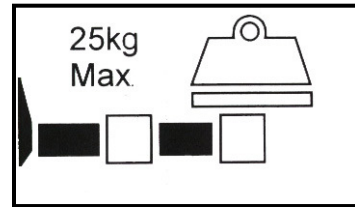
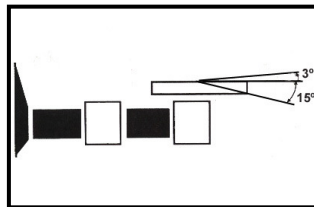
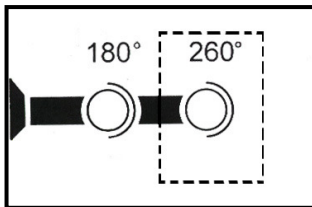
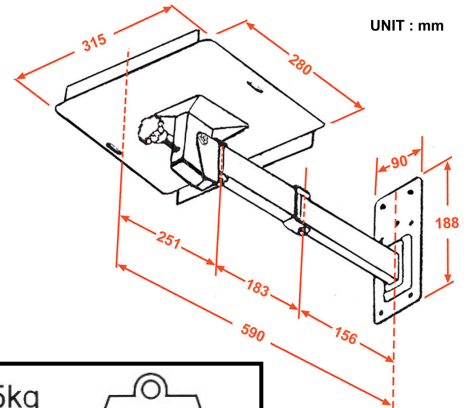
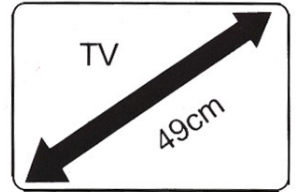
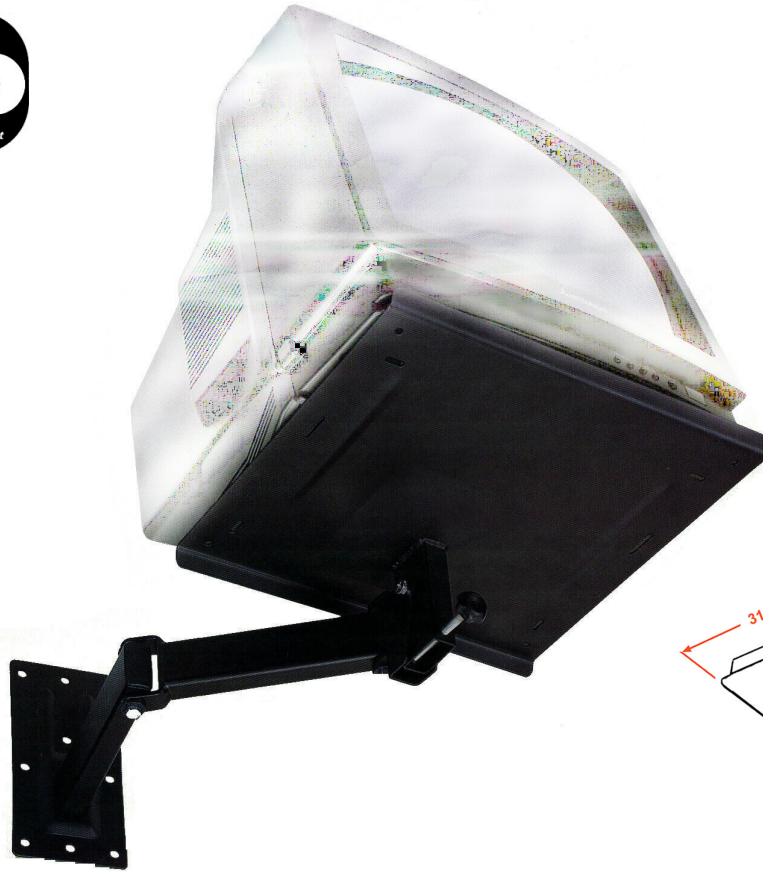

MODEL NO.:	59151	59153
COLOR :	WHITE	BLACK
UNIT PACK :	COLOR BOX + SHRINK	
PACKING :	6 PCS/19.7 KGS/21 KGS/2.3 CUFT	
	20' FCL = 2628 PCS	40' FCL = 5400 PCS



HIMOUNT INDUSTRIAL CO., LTD.
7TH FL., NO. 325, FU HSING N. ROAD.
TAIPEI, TAIWAN, R. O. C.
TEL: 886-2-27135577, 27188886
FAX: 886-2-27152218