

SUPER LIGHT COMPOSITE HEAVY DUTY INDUSTRIAL IMPACT WRENCH

CATALOGUE NUMBER

SPT323

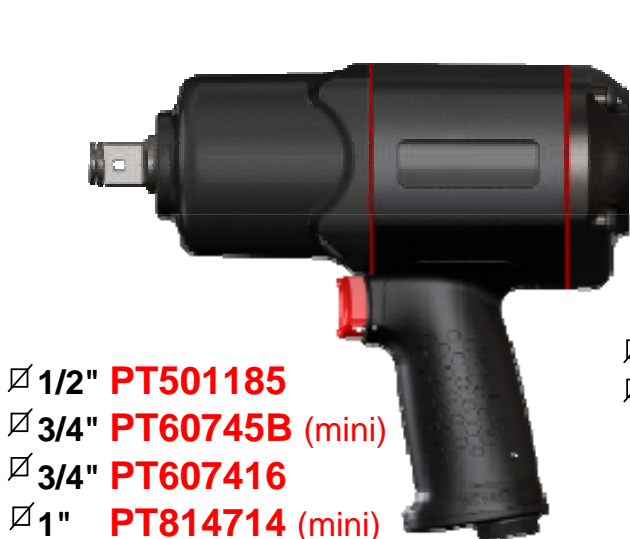

- ∅ 1/2" **PT501185**
- ∅ 3/4" **PT60745B** (mini)
- ∅ 3/4" **PT607416**
- ∅ 1" **PT814714** (mini)



- ∅ 1" **PT814722**
- ∅ 1" **PT814722-2**
(Extended 6")



Blade with spring mounted
Stainless steel (304) Spring
Better design to work more smooth



Industrial Cast iron cylinder
Cylinder Material **FCD45**
Heat treatment HRC
47~52 °



Auxiliary handle & Front cover
can be adjusted in **four directions**
w/ **impact-resistant housing**



Air inlet can be adjusted in **six directions**



Model No	Mechanism	SQ. Drive	Speed rpm	Max. Torque		Air Cons. L/min.	Air Inlet	Hose Size	Noise Level dBA	Weight	
				ft-lbs	Nm					KGS	LB
PT501185	Twin Hammer	1/2"	8500	950	1283	158	1/4"	3/8"	91.5	1.65	3.64
PT60745B	Twin Hammer	3/4"	8500	900	1215	158	1/4"	3/8"	91.5	1.85	4
PT607416	Twin Hammer	3/4"	6000	1550	2092	198	3/8"	3/8"	96.5	3.0	6.6
PT814714	Twin Hammer	1"	6000	1550	2092	198	3/8"	3/8"	96.5	3.15	6.9
PT814722	Twin Hammer	1"	5500	2200	2970	212	1/2"	1/2"	98.5	5.7	12.56
PT814722-2	Twin Hammer	1"	5500	2200	2970	212	1/2"	1/2"	98.5	6.8	15



HIMOUNT INDUSTRIAL CO., LTD.
7TH FL. No.325, FU HSING N. ROAD.TAIPEI, TAIWAN
TEL: 886-2-27135577 886-2-27188886
FAX: 886-2-27152218
<http://www.himount.com/>
E - MAIL: info@himount.com